

4000 Series Air Gap Sensor System

Datasheet

Bently Nevada Machinery Condition Monitoring

167885 Rev. J

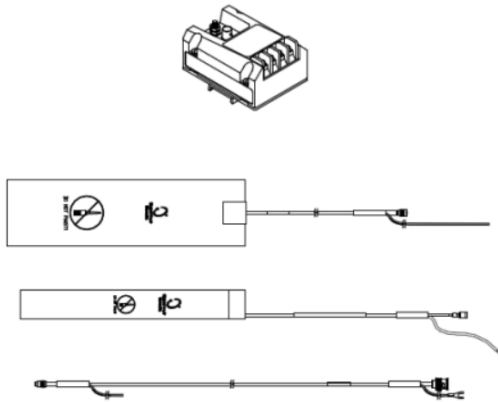

Description

Bently Nevada's Air Gap monitoring system provides monitoring and diagnostic capability for all new and existing hydro generators and motor/generators. Air gap monitoring is fully integrated with the 3500/System 1 platform and utilizes the 3500/46M Hydro Monitor. The 4000 Series air gap sensor system is available in 20 mm and 50 mm ranges for optimal resolution across a wide range of measurement requirements.

Criticality

Air gap is a measure of the distance between rotor and stator in a hydroelectric generator. Monitoring of air gap is critically important because both the stator and the rotor on large hydroelectric machines can be quite flexible and their shape and location are affected by operating centrifugal, thermal, and magnetic forces. Off-center or out-of-round conditions will at least reduce operating efficiency and, in more severe cases, can lead to damage from magnetically induced heating or a rotor-to-stator rub.

Measuring Air Gap

Air gap monitoring utilizes multiple specially designed capacitive proximity probes that are mounted on the inner bore of the generator stator in one or more planes. Measurements are made from the stator bore to each rotor pole as the rotor turns. Minimum air gap dimension and location along with rotor shape are directly measured during unit operation. Stator shape is calculated utilizing the multiple air gap probes. The air gap monitoring system provides operations and maintenance personnel with early warning of impending problems with shape and concentricity of the generator rotor and stator.



Typical Benefits

Air gap dimensions along with rotor and stator shape cannot be effectively measured with the generator out of service because of the combined effects of centrifugal, thermal, and magnetic forces. Early detection of air gap anomalies will facilitate condition-based maintenance by allowing the user time to plan for repairs before scheduled outages. Long term trending of gap and shapes can be correlated with operating conditions and used in operational and rehabilitation planning. Knowing the rotor and stator shapes and minimum air gap dimensions will provide the operator with the information needed to remove a machine from service before serious damage like that from a rotor stator rub occurs.

Air Gap Probe and Extension Cable

The 4000 series Air Gap probe is designed for maximum survivability in the harshest hydro generator environment. It can continually operate and maintain its accuracy in temperatures up to +125 °C (+257 °F). The probe can also continually operate and maintain its accuracy in the 1.5 Tesla magnetic field often experienced between the rotor pole and the stator. ClickLoc connectors come standard on both the probe and extension cable to prevent loosening of the connectors.

Proximitor Sensor

The 4000 series Air Gap Proximitor Sensor is based upon our best selling 3300 XL Proximitor Sensor technology. The Proximitor Sensor uses a DIN rail connection to ease installation and to minimize the number of cumbersome screws required when working around the hydro generator. The grounding stud on the Proximitor Sensor features a safety thread in order to ensure the locking nut does not inadvertently fall off during the installation of the ground wire on the extension cable.

Specifications

 Unless otherwise noted, the following specifications are for a 4000 Series Air Gap Proximity Sensor, extension cable, and probe between 0 °C and +50 °C (+32 °F to +122 °F), with a +24 Vdc power supply, and a 10kΩ load.

Electrical

Proximity Sensor Input	Accepts one non-contacting 4000 Series Capacitive Probe and Extension Cable.
Power	Requires +23.25 Vdc to +24.75 Vdc at 85 mA maximum consumption.
Supply Sensitivity	Less than 2 mV change in output voltage per volt change in input voltage.
Output Resistance	50 Ω ± 5%.
Extension Cable Capacitance	75.5 pF/m (23.0 pF/ft) typical.
Field Wiring	0.2 to 1.5 mm ² (16 to 24 AWG). Recommend using two-conductor shielded cable. Recommended maximum length of 305 metres (1000 feet) between the 4000 Series Proximity Sensor and the monitor.

Linear Range

20 mm System	18.3 mm (720 mils). Linear range begins at approximately 2 mm (80 mils) from the face of the probe and is from 2 to 20.3 mm (80 to 800 mils) (approximately +1 to +10 Vdc).
50 mm System	45.7 mm (1800 mils). Linear range begins at approximately 5.1 mm (200 mils) from the face of the probe and is from 5.1 to 50.8 mm (200 to 2000 mils) (approximately +1 to +10 Vdc).

Average Scale Factor (ASF)

20 mm System	0.50 mV/mm (12.5 mV/mil), nominal
50 mm System	0.20 mV/mm (5.0 mV/mil), nominal

Deviation from a Straight Line

20 mm System	Less than ±1.02 mm (±40 mils) with system between 0 °C and +50 °C (+32 °F and +122 °F).
50 mm System	Less than ±2.54 mm (±100 mils) with system between 0 °C and +50 °C (+32 °F and +122 °F).
Frequency Response	0 to 2.0 kHz: +0, -3 dB typical with up to 305 metres (1000 feet) of field wiring.

Mechanical

Probe Material	FR4 type material
Probe and Extension Cable Material	75 Ω triaxial, fluoroethylene propylene (FEP) cable
Proximity Sensor Material	Aluminum
Tensile Strength (maximum rated)	312 N (70 pounds) probe lead to probe. 89 N (20 pounds) at probe lead to extension cable connectors
Connector Material	Gold-plated brass and gold-plated beryllium copper

Connector-to-connector Torque

Recommended Torque	Finger tight.
Maximum Torque	0.565 N•m (5 lbf•in).
Minimum Bend Radius	25.4 mm (1.0 in).

System Mass (typical)

Probe	Approximately 140 g (0.3 lbs).
Extension Cable	Approximately 320 g (0.7 lbs).
Proximity Sensor	Approximately 380 g (0.8 lbs).

Environmental Limits

Probe Temperature Range

Operating Temperature	0 to +125 °C (+32°F to +257 °F).
Storage Temperature	-35°C to +125 °C (-31°F to +257 °F).

Extension Cable Temperature Range

Operating Temperature	0°C to +125°C (+32°F to +257°F).
Storage Temperature	-35°C to +125 °C (-31°F to +257°F).

Proximitior Sensor Temperature Range

Operating Temperature	0°C to +70°C (+32°F to +158°F).
Storage Temperature	-35°C to +85°C (-31°F to +185°F).
Relative Humidity	Less than a 5% change in average scale factor when tested in 93% humidity in accordance with IEC standard 60068-2-78 for up to 56 days.

Compliance and Certifications

FCC

This device complies with part 15 of the FCC Rules. Operation is subject to the following two conditions:

- This device may not cause harmful interference.
- This device must accept any interference received, including interference that may cause undesired operation.

RoHS

RoHS Directive 2011/65/EU

EMC

EMC Directive 2014/30/EU

Ordering Information



For the detailed listing of country and product specific approvals, refer to the *Approvals Quick Reference Guide* (108M1756) available from Bently.com.

4000 Series Air Gap Probes

400102 Air Gap 50 mm Probe

400202 Air Gap 20 mm Probe

Product Number-AA	
A: Cable Length Option	
01	Standard, 18 inches

Includes:

- Air gap probe with integral cable and connector
- Teflon conduit, 12.7 mm (1/2 inch) diameter, 431 mm (17 inch) long
- Loop strap clamp and 1/4 - 20 bolt
- Tube of silicon adhesive (12 month shelf life)
- Adhesive applicator
- Two (2) fiberglass spacers (for 50 mm air gap probes only)

4000 Series Air Gap Proximator Sensor

400100 Air Gap 50 mm Proximator Sensor

400200 Air Gap 20 mm Proximator Sensor

Product Number-AAA-BB	
A: Cable Length Option	
100	10.0 metres (33 feet) system length
B: Linear Range Option	
02	20 mm (0.8 inches)

4000 Series Extension Cable

400130 Air Gap 50 mm Extension Cable

400230 Air Gap 20 mm Extension Cable

Product Number-AAA	
A: Cable Length Option	
100	10.0 metres (33 feet) system length

Accessories

167684	Air Gap Transducer System Operation User Guide
02200627	+24 Vdc Power Supply. Typically 2 sensor systems will be powered by 1 power supply in each Proximator Housing. The power supply is capable of running 4 sensor systems.
330181	3300 XL Proximator Housing. Suggested configuration is 330181-01-00-01-00-00; a housing with DIN mount hardware, no conduit fitting, standard 2.34 mm (0.092 in) gland plate thickness, no terminal blocks, and no approvals. Typically 2 sensor systems and 1 power supply will be located in each housing. The housing is capable of holding 1 power supply and 4 Proximator Sensors.
02173006	Bulk Cable (specify length in feet) 1.0 mm ² (18 AWG), 2-conductor, twisted, shielded cable used for the PROX OUT signal on the Air Gap Proximator Sensor terminal strip.
168448-01	Air Gap Verification Kit.
173873	7-inch PEEK cable ties suitable for hydro generator environments, bag of 50
167276	Tube of silicon adhesive (12 month shelf life)

Graphs and Figures

Unless otherwise specified, dimensions are in mm (inches).

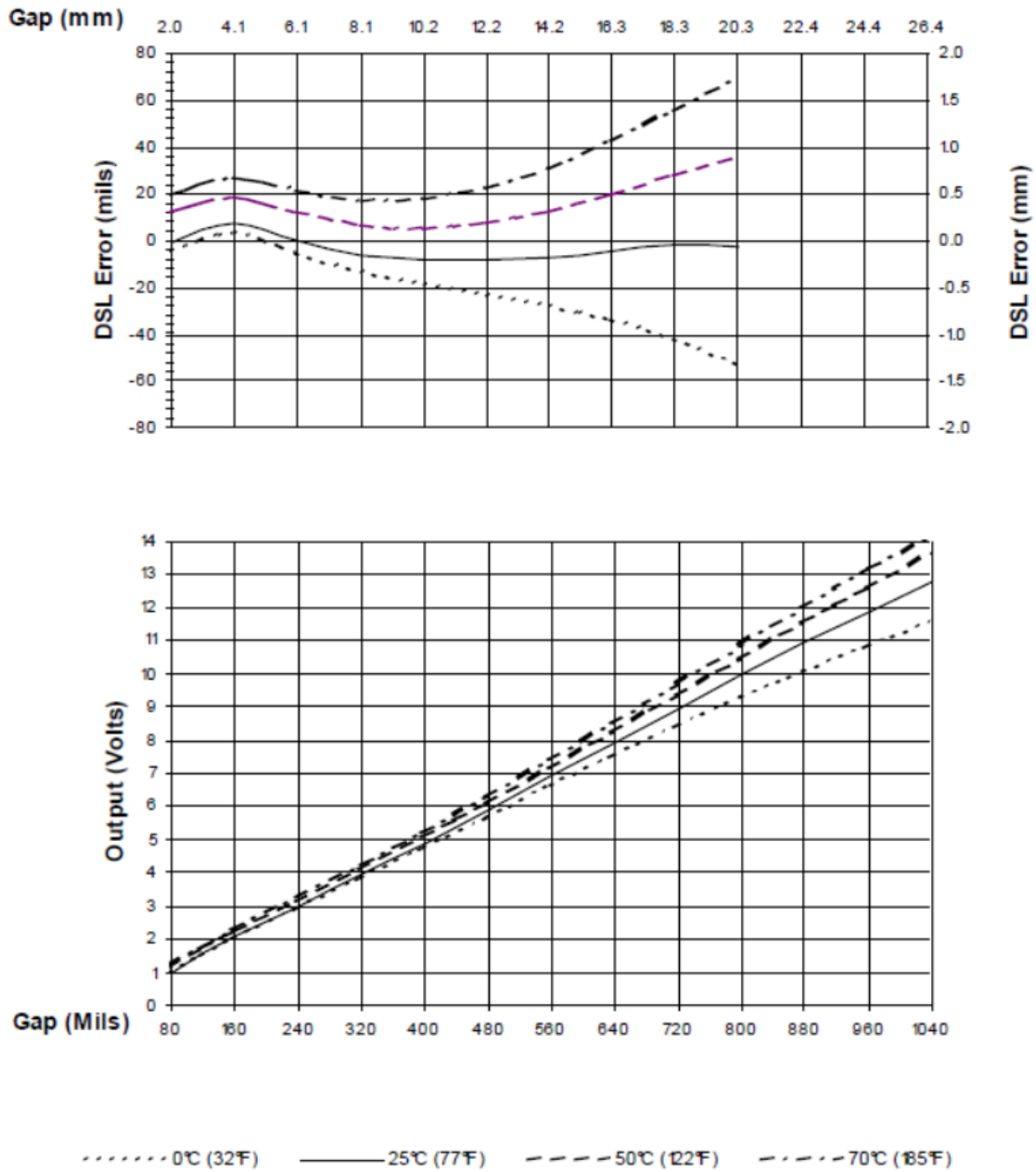

Figure 1: Typical Air Gap 20 mm Proximity Sensor Over Temperature

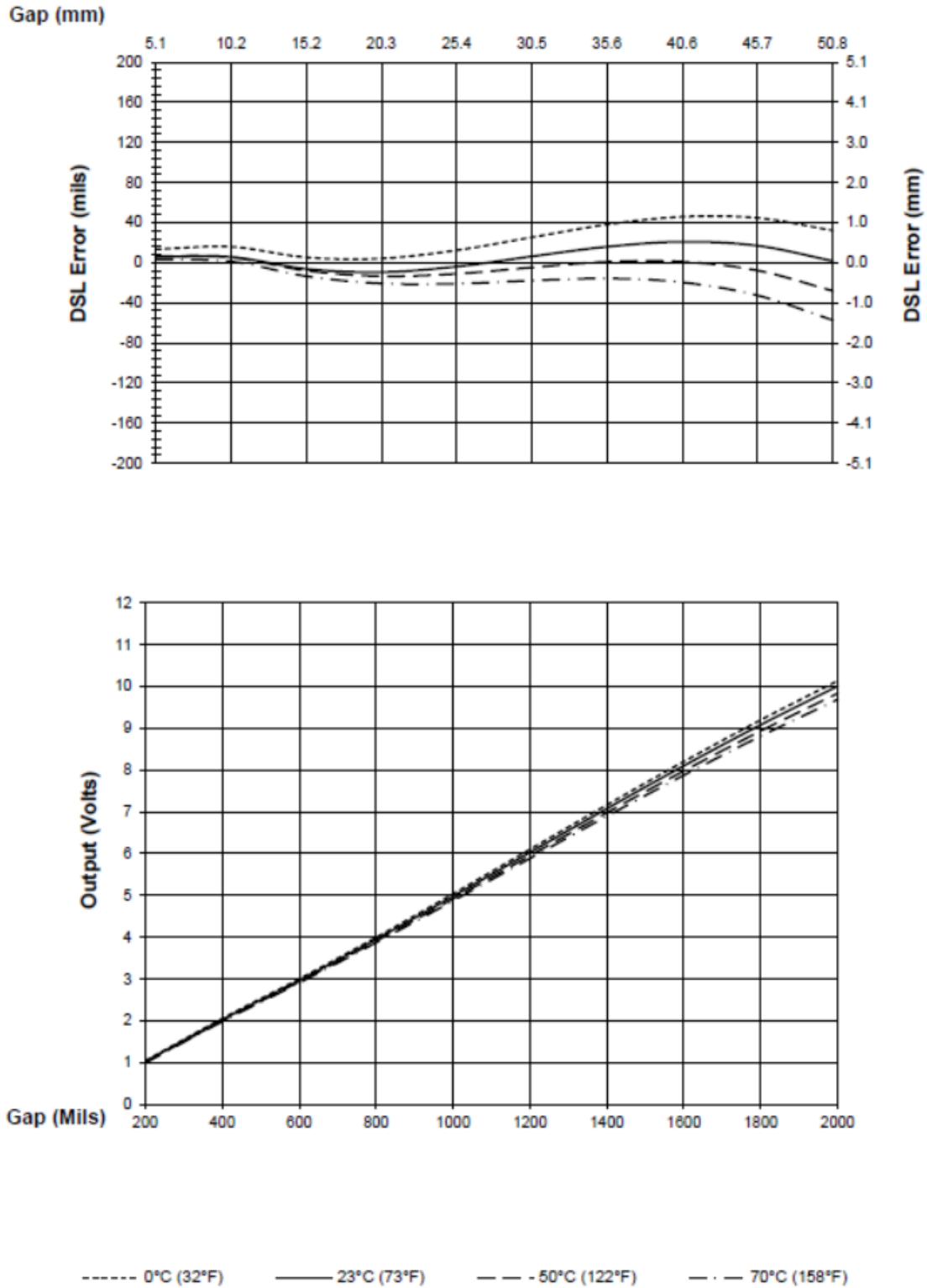

Figure 2: Typical Air Gap 50 mm Proximity Sensor Over Temperature

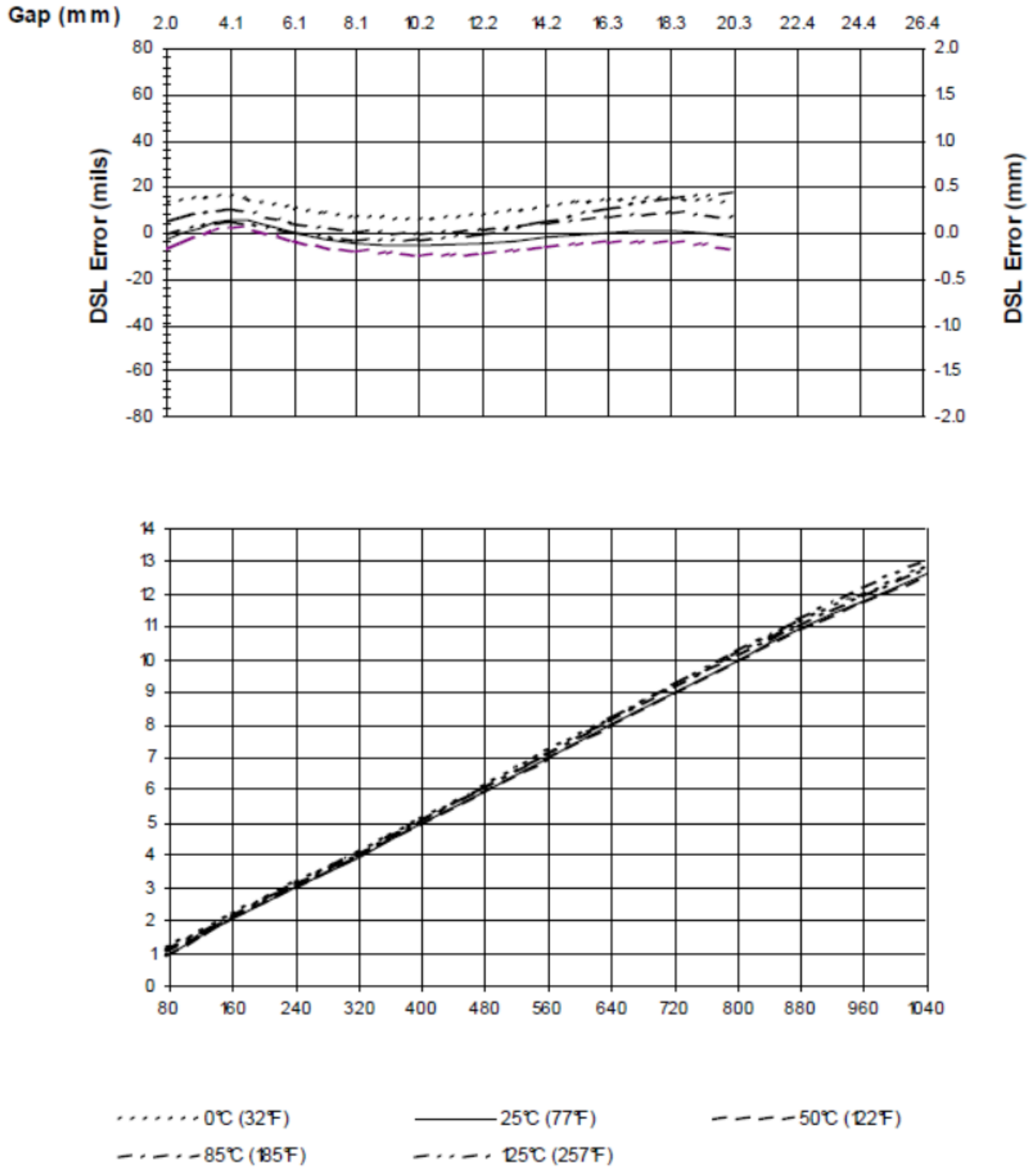

Figure 3: Typical Air Gap 20 mm Probe Over Temperature

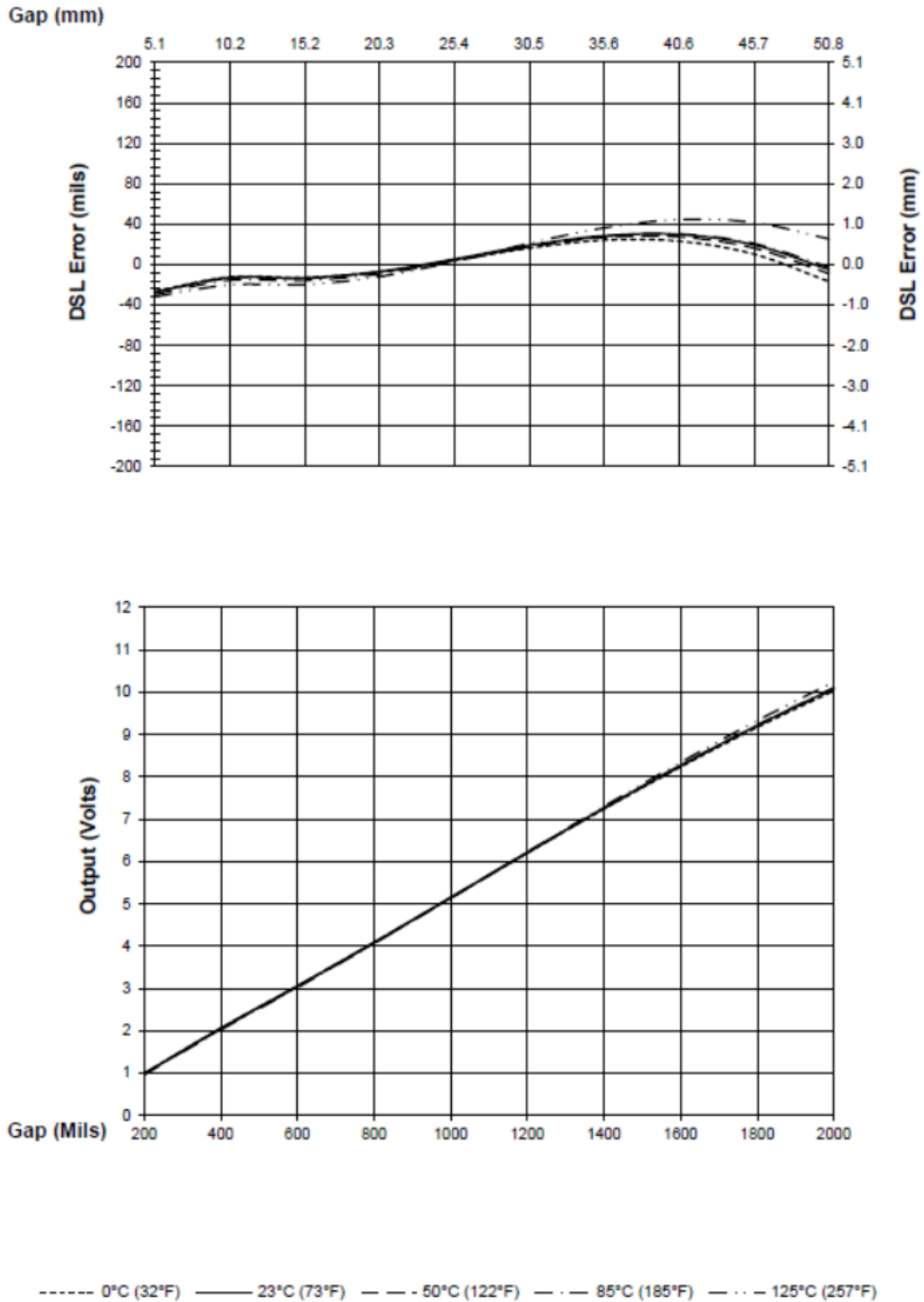

Figure 4: Typical Air Gap 50 mm Probe Over Temperature

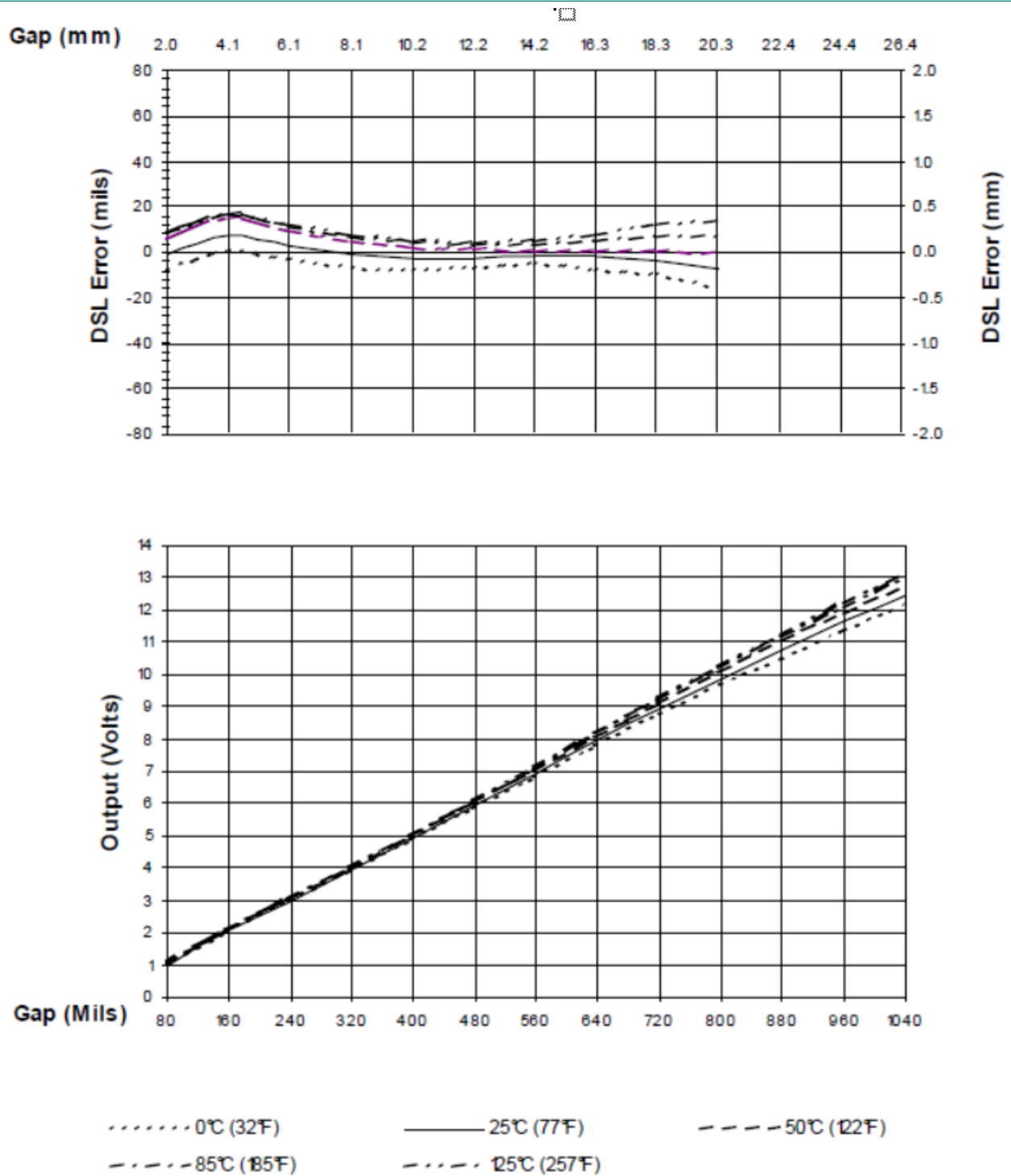

Figure 5: Typical Air Gap 20 mm Cable Over Temperature

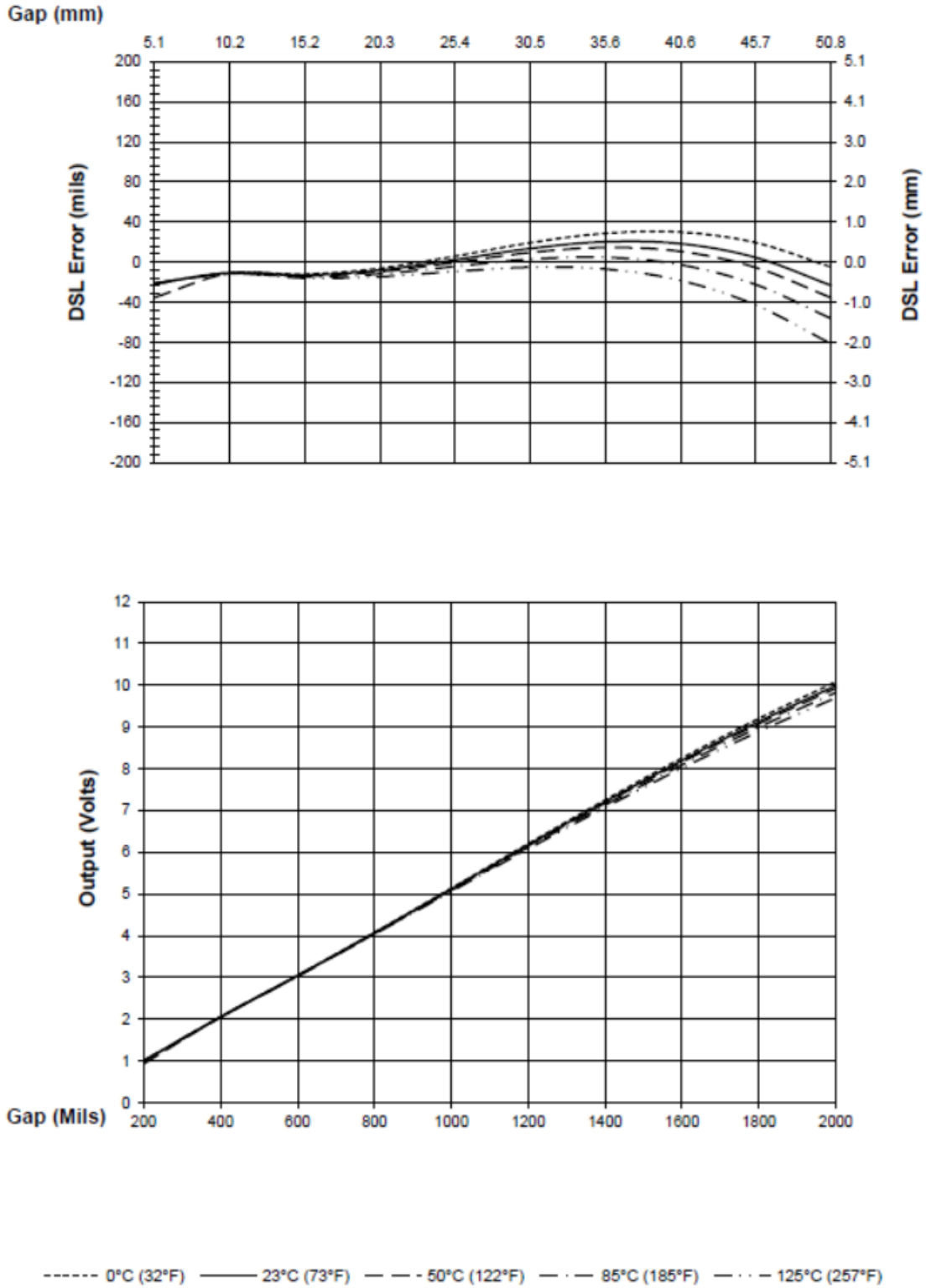

Figure 6: Typical Air Gap 50 mm Cable Over Temperature

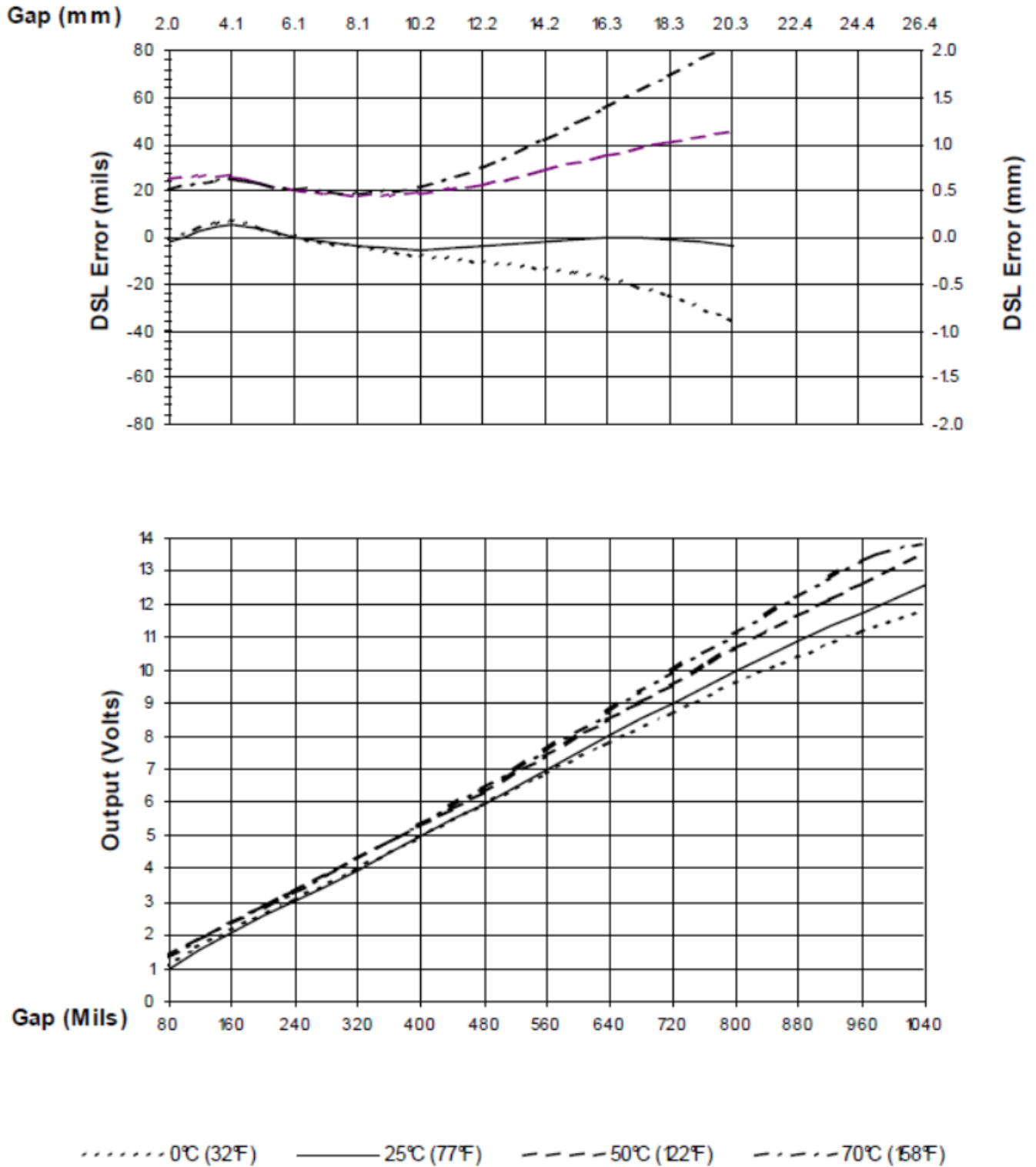

Figure 7: Typical Air Gap 20 mm Sensor System Over Temperature

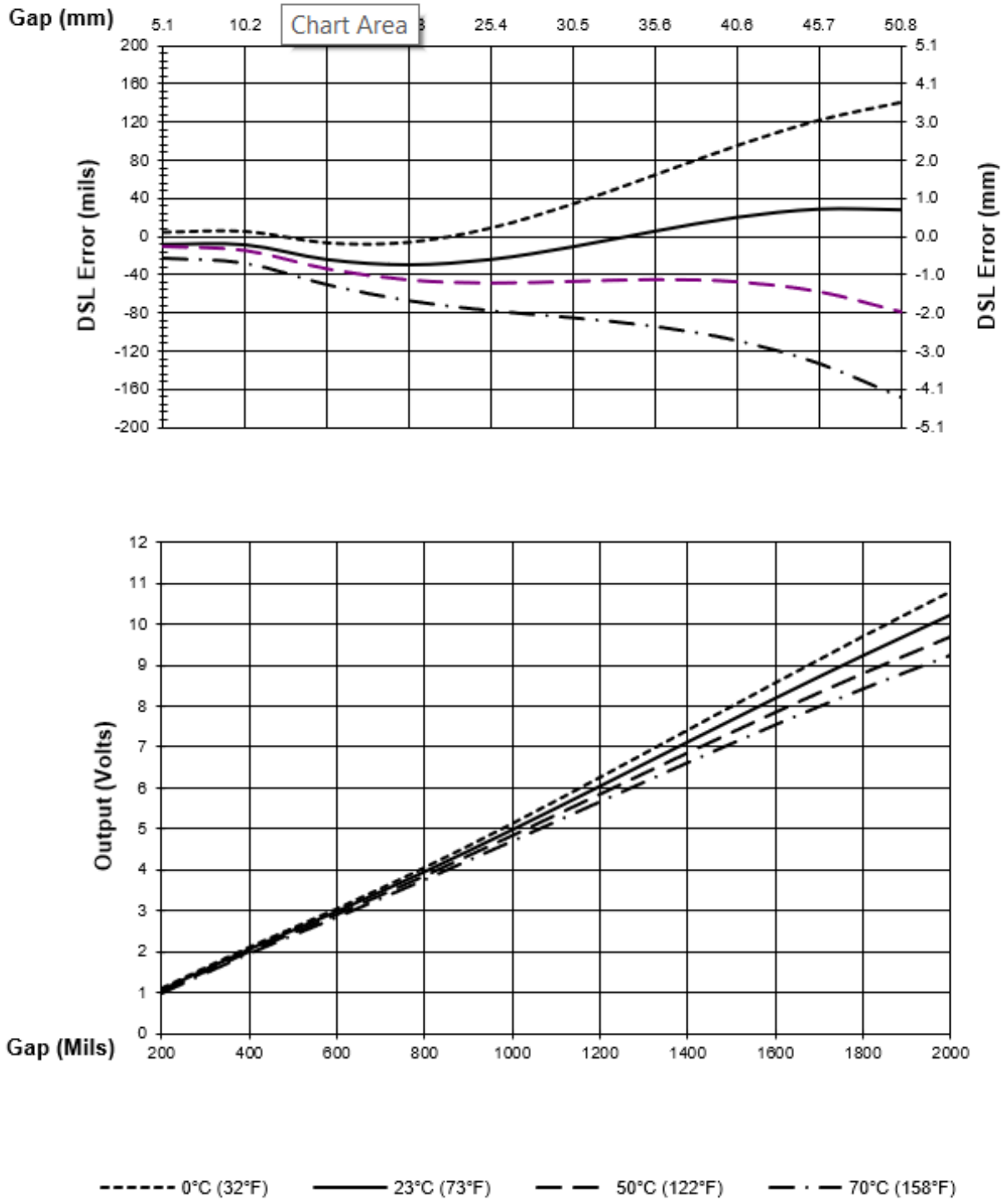

Figure 8: Typical Air Gap 50 mm Sensor System Over Temperature

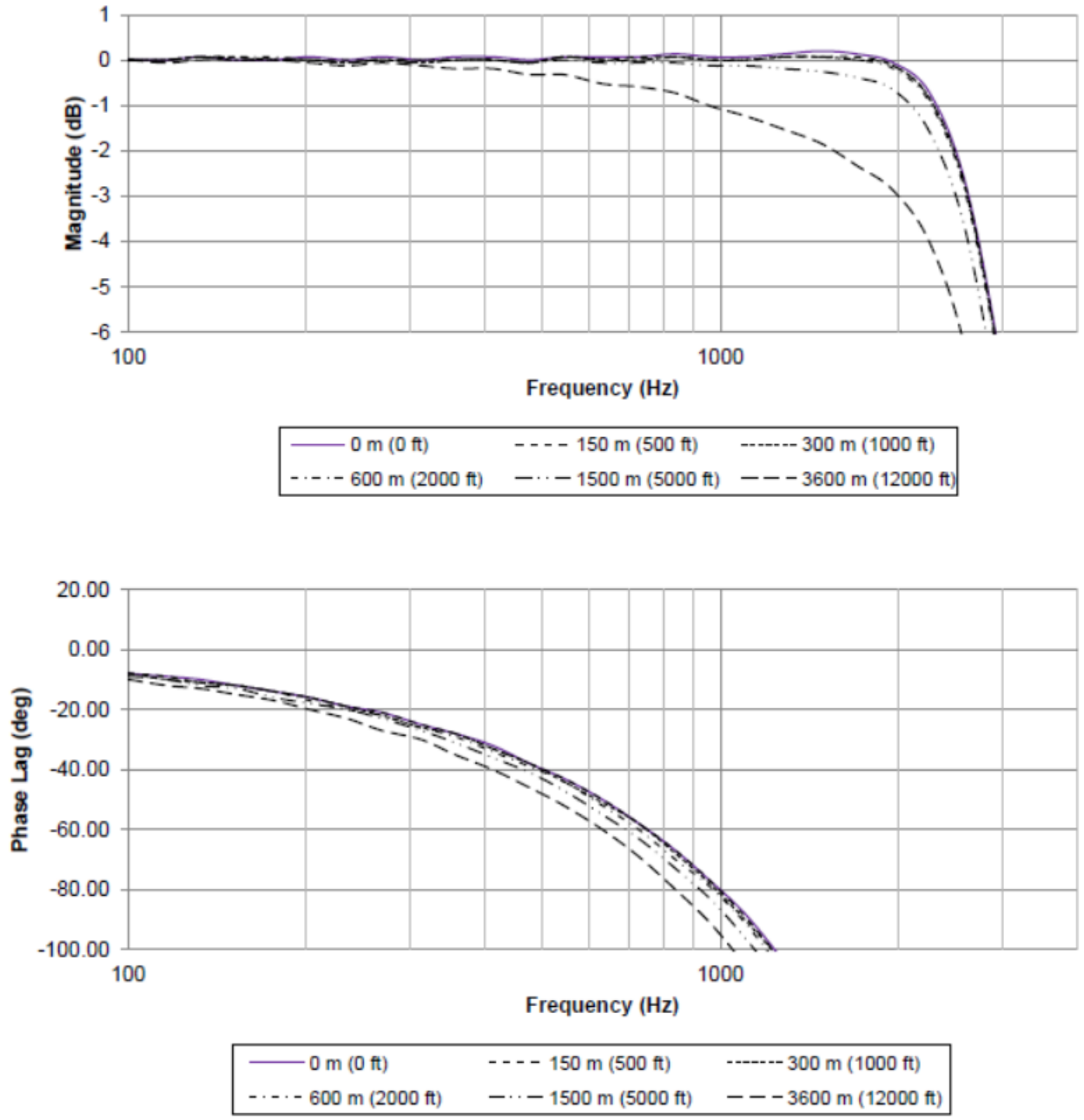

Figure 9: Air Gap Frequency Probe

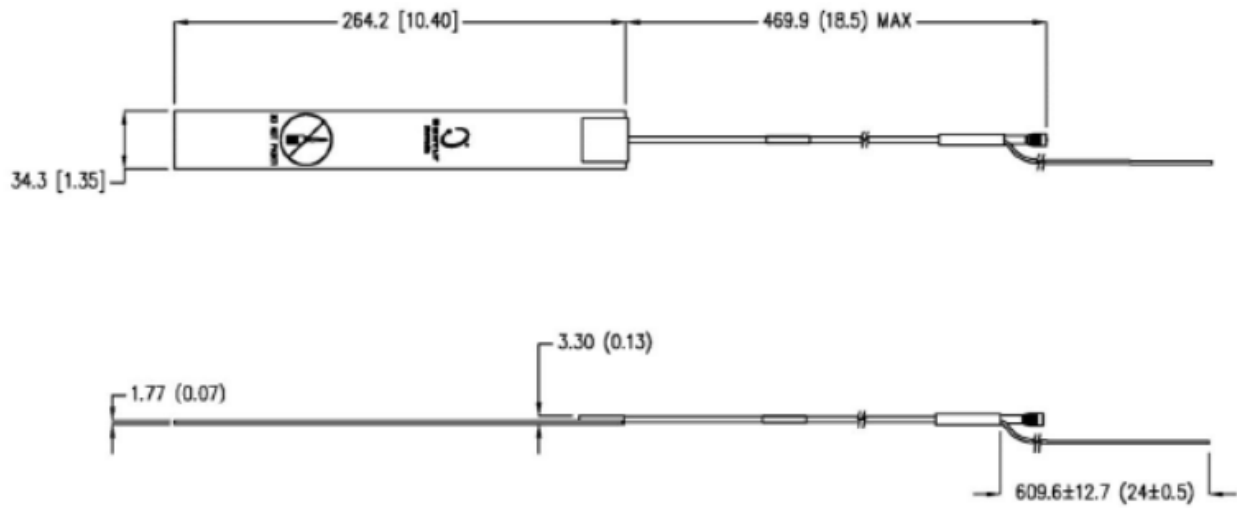

Figure 10: Air Gap 20 mm Probe

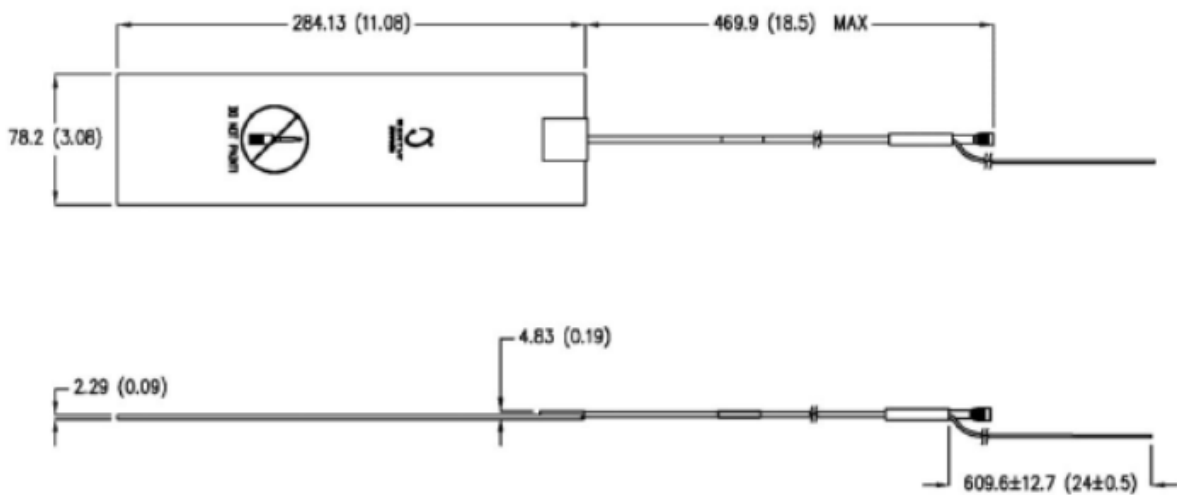

Figure 11: Air Gap 50 mm Probe

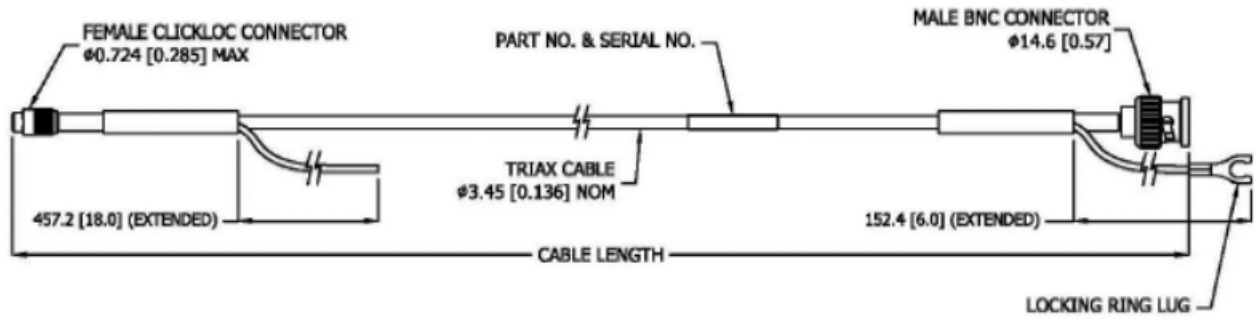

Figure 12: Air Gap 20 mm or 50mm Extension Cable

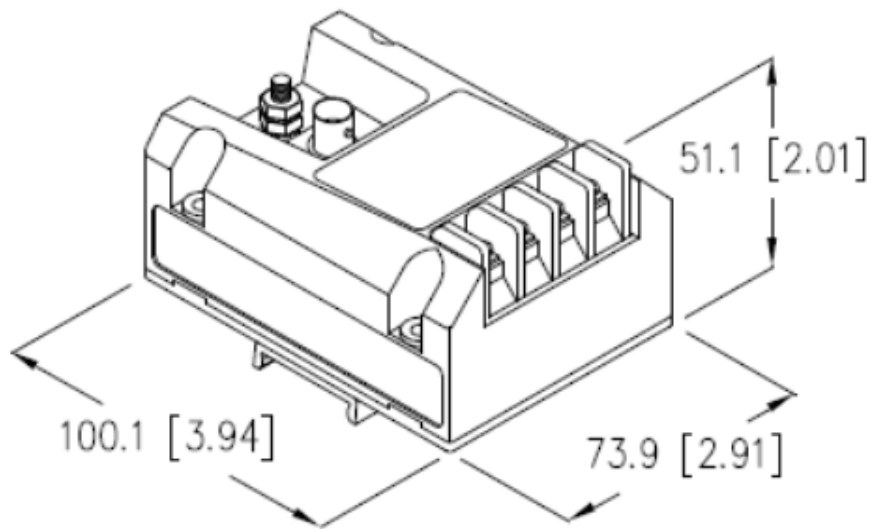

Figure 13: Air Gap 20mm or 50 mm Proximito Sensor

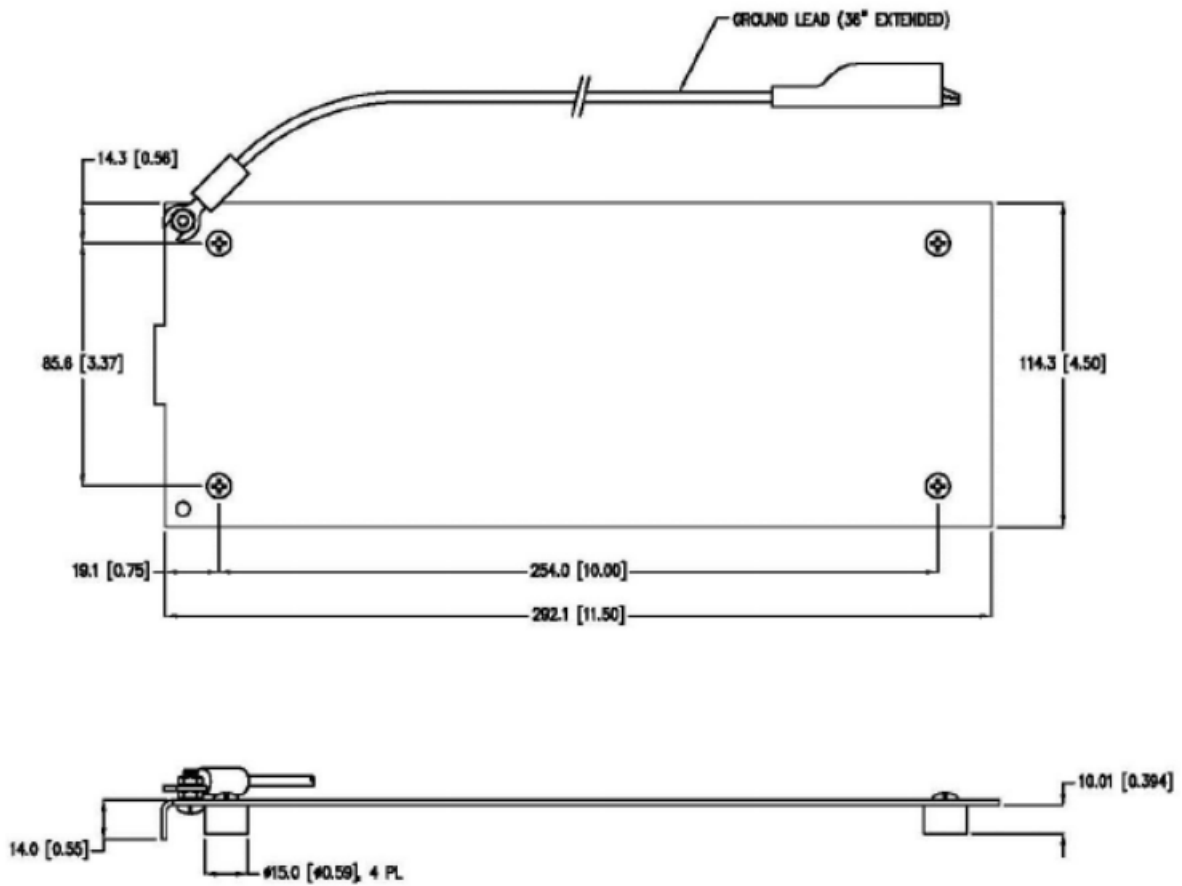

Figure 14: Air Gap Verification Fixture